



Rev. 11/2023

SAFETY RELIEF VALVES CERTIFIED AND STANDARD

SAFETY RELIEF VALVES CERTIFIED AND STANDARD



CONTROLLED RISE STANDARD SAFETY RELIEF VALVES (COMPLIANT WITH DIRECTIVE PED 2014/68/EU) AND THE PRESSURE EQUIPMENT (SAFETY) REGULATIONS 2016

		Φ ORIFICE				D _N = 15mm				
		FF		MF		FF		MF		
Connections										
Pressure Gauge Connection									Female 1/4" UNI-EN-ISO 228	
Φ Coupling	D _i = 1/2"	D _i = 3/4"	D _i = 1/2"	D _i = 1/2"	D _i = 1/2"	D _i = 3/4"	D _i = 1/2"	Flow rate of discharge [Kg/h]	Max Generator Potential P=P _t +20%P _t [KW]	
Φ Discharge	D _s = 1/2"	D _s = 3/4"	D _s = 1/2"	D _s = 3/4"	D _s = 1/2"	D _s = 3/4"	D _s = 1/2"			
Discharge Coefficient	K=0,47	K=0,47	K=0,47	K=0,47	K=0,47	K=0,47	K=0,47			
Discharge Coefficient certificate	K=0,42	K=0,42	K=0,42	K=0,42	K=0,42	K=0,42	K=0,42			
Calibration Pt [bar]	Code		Code		Code		Code			
1,50	351.04.10	351.05.10	352.04.10	352.05.10	353.04.10	353.05.10	354.04.10	84	48	
2,00	351.04.20	351.05.20	352.04.20	352.05.20	353.04.20	353.05.20	354.04.20	102	55	
2,50	351.04.30	351.05.30	352.04.30	352.05.30	353.04.30	353.05.30	354.04.30	119	68	
3,00	351.04.40	351.05.40	352.04.40	352.05.40	353.04.40	353.05.40	354.04.40	136	75	
3,50	351.04.50	351.05.50	352.04.50	352.05.50	353.04.50	353.05.50	354.04.50	154	83	
4,00	351.04.60	351.05.60	352.04.60	352.05.60	353.04.60	353.05.60	354.04.60	170	96	
4,50	351.04.70	351.05.70	352.04.70	352.05.70	353.04.70	353.05.70	354.04.70	187	103	
5,00	351.04.80	351.05.80	352.04.80	352.05.80	353.04.80	353.05.80	354.04.80	204	109	
6,00	351.04.90	351.05.90	352.04.90	352.05.90	353.04.90	353.05.90	354.04.90	238	128	
7,00	351.04.71	351.05.71	352.04.71	352.05.71	353.04.71	353.05.71	354.04.71	272	148	
8,00	351.04.81	351.05.81	352.04.81	352.05.81	353.04.81	353.05.81	354.04.81	310	166	
10,00	351.04.11	351.05.11	352.04.11	352.05.11	353.04.11	353.05.11	354.04.11	380	181	

Overpressure opening

Less than $[20\% di P_t]$ - EN 4126-1

Closing discard

Less than $[20\% di P_t]$ - EN 4126-1

Max admissible pressure

$P_s = 10$ bar

Backpressure

Atmospheric

Operating temperature

$+5^\circ\text{C} \div +110^\circ\text{C}$

Fluid of use Water

Electrothermally controlled servomotor
with auxiliary microswitch (4-wire)

DIMENSIONAL FEATURES

351.0X.XX (FF)
352.0X.XX (MF)

CE UK
CA
0425 1521

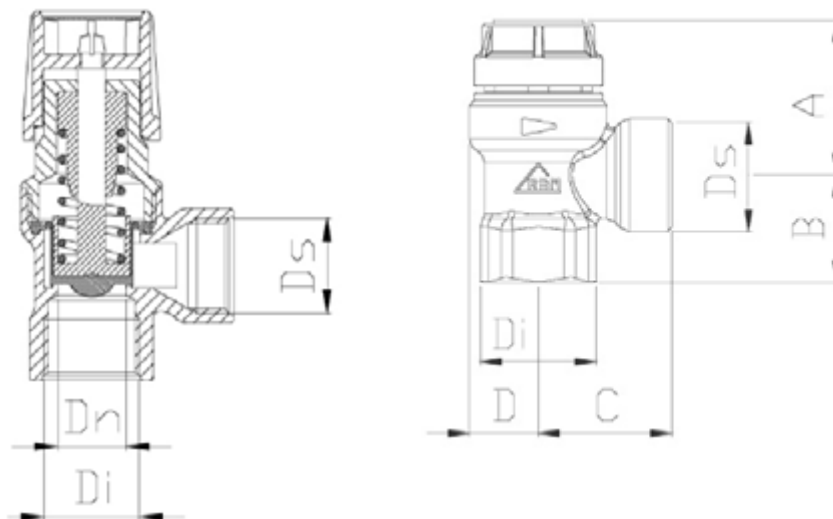

ORDINARY VALVES WITHOUT MANOMETER

Code	D_i	D_s	A [mm]	B [mm]	C [mm]	D [mm]
351.04.XX	1/2"	1/2"	35,5	25	31	16
351.05.XX	3/4"	3/4"	35,5	28	34	16
352.04.XX	1/2"M	1/2"	35,5	27	31	16
352.05.XX	1/2"M	3/4"	35,5	29,7	33	15,5

353.0X.XX (FF)
354.04.XX (MF)

CEUK
CA
0425 1521

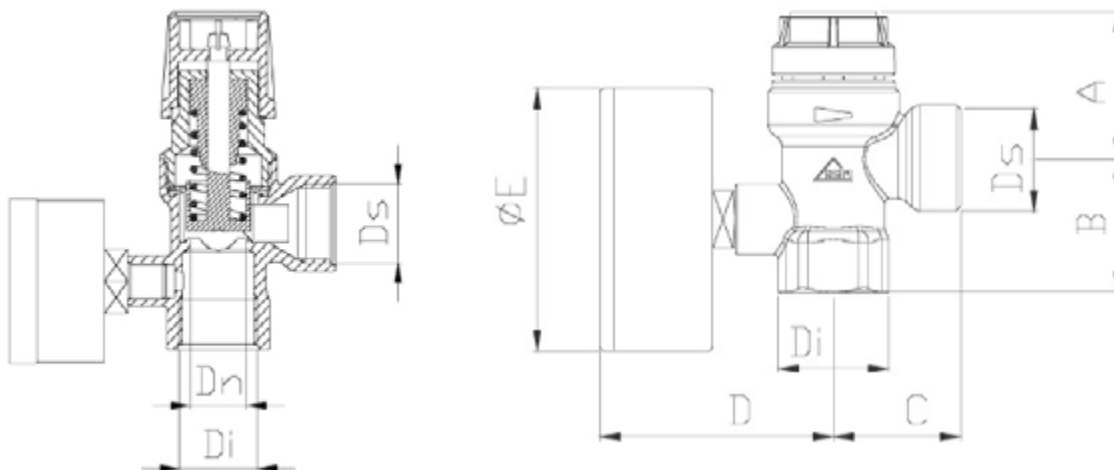

ORDINARY VALVES WITH MANOMETER

Code	D _i	D _s	A [mm]	B [mm]	C [mm]	D [mm]	ø E [mm]
353.04.XX	½"	½"	35,5	33	31	63,5	51,5
353.05.XX	¾"	¾"	35,5	40,5	34	63,5	51,5
354.04.XX	½"M	½"	35,5	35	31	63,5	51,5

CONSTRUCTION FEATURES

Body	Brass
Molla	stainless steel INOX AISI 302
Shutter Seal	EPDM PEROX
Diaphragm	EPDM PEROX
Connections	Angle FF or MF (Male-Female) Threaded UNI-EN-ISO 228
Pressure Gauge Connection (for relative valves)	F ¼" UNI-EN-ISO 228

TECHNICAL FEATURES

Operating temperature:	$+5 \leq T \leq +110 \text{ } ^\circ\text{C}$
Max Admissible Pressure	$P_s = 10 \text{ bar}$
Calibration pressure:	$1,5 \leq P_t \leq 10 \text{ bar}$ (see initial tab.)
Backpressure	Atmospheric
Opening overpressure	$< 20\% \text{ di } P_t$
Closing discard	less than [20% of Pt]
Orifice diameter	$D_n = 15 \text{ mm}$ (see initial tab.)
Net section (A)	$A = 1,76 \text{ cm}^2$ (see initial tab.)
Max potential Generator	$48 \div 181 \text{ KW}$ (see initial tab.)
Fluid of use	water- air (Group 2)
Pressure Gauge Scale (for relative valves)	0÷4 bar for valve $\leq 3 \text{ bar}$ 0÷10 bar for valve $> 3 \text{ bar}$

DESCRIPTION

Description of appliance:

The valve is a safety accessory according to the definition of PED Directive 2014/68/EU of the type "direct pressure limitation" and has been built in compliance with standard EN 4126-1 and the "R Collection" of ISPEL technical standards (only series 605 valve).

The gasket sealing the cut-off valve is built with materials suitable to guarantee resistance to wear and without sticking to the housing, even when operating for long periods of time.

The immovable plate prevents unintentional tampering with valve calibration and bears the calibration value, the product code, DN, TS, PS, Kw, discharge pressure, usable fluids group, batch identification, progressive construction number, year of manufacture.

DESCRIPTION OF OPERATION:

When there is an over-pressure of no more than 10% the value of the calibration pressure, the valve opens a discharge orifice (the force generated by the pressure overcomes the resistance exerted by the valve spring), allowing part of the fluid to be discharged and thereby lower the pressure inside the system.

This orifice is closed by a spring when the pressure value drops to a value within a maximum of 20% Pt.

Triggering of the safety valve is guaranteed even if the diaphragm breaks.

Turning the hand wheel anticlockwise opens and closes the discharge orifice.

The valve is supplied with a threaded part after the discharge orifice where a unit (supplied separately) which visually controls that the valve has triggered is mounted.

Standard safety relief valves

(Series 351 - 352 - 353 - 354)

USE

These are mainly used to control the pressure in hydraulic circuits and heat generators with a useful thermal power of less than 35 Kw and in all cases not requiring the use of a certified valve.

For hot water storage heaters intended for consumption, it is possible to use valves manufactured according to the requirements set forth by MD 1.12.75 and by "Collection R" technical specification (R.1.A3).

CHOICE

To choose a standard safety relief valve for the protection of hot water heaters, it is necessary to observe the following requirements:

- orifice diameter of no less than 15mm (for a storage heater with Volume max = 1125 litres)
- calibration pressure not exceeding the maximum operating pressure.

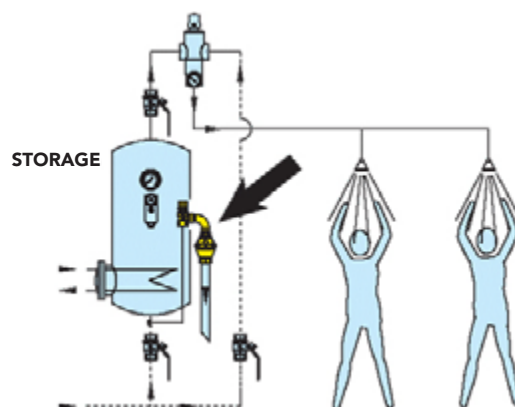

In any case, for the correct use and the correct location of the safety relief valves, always refer to the regulation and specific legislation in force: this document only underlines the most important requirements.

CERTIFICAZIONI - RIFERIMENTI NORMATIVI

- **Directive PED 2014/68/EU**

(Valve Series 351 - 352 - 353 - 354):

Consult declarations of conformity No. DC0351.0 available at www.rbm.eu

- **The Pressure Equipment (Safety) Regulations**

(Valvole Serie 351 - 352 - 353 - 354):

Consult declarations of conformity n° DC0351.1 available at www.rbm.eu

GENERAL WARNINGS FOR INSTALLATION AND USE

- The safety valve must be mounted on the system paying attention to the direction of flow specifically indicated on the body.
- The safety valve must be mounted on the top of the storage tank making sure it completely emerges in it (standard valve Series 351 - 352 - 353 - 354)
- The safety valve can be mounted both horizontally and vertically, making sure the discharge does not face upwards.
- The inside diameters of the fluid supply and discharge pipes of the safety valve must be no less than their DN.
- The pipes or accessories used to transport discharged fluids must not create bending moments which jeopardise triggering of the valve.
- The equipment, pipes or accessories used to transport fluids must be free at the threadings from residue of prior preparations or processes especially when the water contains inhibitors capable of developing amines.
- Intentional tampering with the calibration value makes it impossible for the valve to perform the safety function for which it was designed.
- The safety unit should be opened manually once a year to check its

efficiency.

- In the event of fluid leakage, pay great attention to interventions on the valve, taking the necessary precautionary measures, especially in the presence of very high operating temperatures.
- When the cut-off valve has difficulty restoring its sealing features, after discharge interventions, perform some opening and closing manoeuvres by manually turning the hand wheel of the valve anti-clockwise, thus cleaning the concerned parts.
- If the RBM safety valve is not installed and kept in a suitable place, it does not lose its functional and performance features.
- The RBM safety valve must be installed by qualified technicians.
- The valve must be inspected periodically starting from the commissioning date, at a frequency established by legislation in force.

The instructions herein must be complied with mandatorily.

SPECIFICATION ITEMS

SERIES 351

Ordinary diaphragm safety valve with controlled lift for neutral fluids and gases. FF connection 1/2 "x1/2" and 3/4 "x3/4". Brass body. AISI 302 stainless steel spring. EPDM PEROX plug seal. EPDM PEROX diaphragm. Threaded FF UNI-EN-ISO 228 corner connections. Max. permissible pressure PS 10 bar. Max. operating temperature 110 °C. Orifice diameter 15 mm. Opening overpressure < 20% of Pt. Closing pressure -20 %. Permissible fluid water-air (Gr.2). Complies with PED Directive 2014/68/EU and The Pressure Equipment (Safety) Regulations 2016 Available calibrations (bar): 1,50 - 2,00 - 2,50 - 3,00 - 3,50 - 4,00 - 4,50 - 5,00 - 6,00 - 7,00 - 8,00 - 10,00.

SERIES 352

Ordinary diaphragm safety valve with controlled lift for neutral fluids and gases. MF connection 1/2 "x1/2" and 1/2 "x3/4". Brass body. AISI 302 stainless steel spring. EPDM PEROX plug seal. Diaphragm in EPDM PEROX. MF UNI-EN-ISO 228 threaded corner connections. Max. permissible pressure PS 10 bar. Max. operating temperature 110 °C. Orifice diameter 15 mm. Opening overpressure < 20% of Pt. Closing pressure -20 %. Permissible fluid water-air (Gr.2). Complies with PED Directive 2014/68/EU and The Pressure Equipment (Safety) Regulations 2016 Available calibrations (bar): 1,50 - 2,00 - 2,50 - 3,00 - 3,50 - 4,00 - 4,50 - 5,00 - 6,00 - 7,00 - 8,00 - 10,00.

SERIES 353

Controlled lift diaphragm safety valve for neutral fluids and gases with dial gauge. FF connection 1/2 "x1/2" and 3/4 "x3/4". Brass body. AISI 302 stainless steel spring. EPDM PEROX plug seal. EPDM PEROX diaphragm. Threaded FF UNI-EN-ISO 228 corner connections. Pressure gauge connection F 1/4" UNI-UN-ISO 228. Max. permissible pressure PS 10 bar. Max. operating temperature 110 °C. Orifice diameter 15 mm. Opening overpressure < 20 % Pt. Closing pressure -20 %. Permissible fluid water-air (Gr.2). Manometer scale 0 ÷ 4 bar for valves < 4 bar and 0 ÷ 10 bar for valves > 4 bar. Complies with PED Directive 2014/68/EU and The Pressure Equipment (Safety) Regulations 2016 Available calibrations (bar): 1,50 - 2,00 - 2,50 - 3,00 - 3,50 - 4,00 - 4,50 - 5,00 - 6,00 - 7,00 - 8,00 - 10,00.

SERIES 354

Controlled lift diaphragm safety valve for neutral fluids and gases with dial gauge. 1/2 "x1/2" MF connection. Brass body. AISI 302 stainless steel spring. EPDM PEROX plug seal. EPDM PEROX diaphragm. MF UNI-EN-ISO 228 threaded corner connections. Pressure gauge connection F 1/4" UNI-UN-ISO 228. Max. permissible pressure PS 10 bar. Max. operating temperature 110 °C. Orifice diameter 15 mm. Opening overpressure < 20 % Pt. Closing pressure -20 %. Permissible fluid water-air (Gr.2). Manometer scale 0 ÷ 4 bar for valves < 4 bar and 0 ÷ 10 bar for valves > 4 bar. Complies with PED Directive 2014/68/EU and The Pressure Equipment (Safety) Regulations 2016 Available calibrations (bar): 1,50 - 2,00 - 2,50 - 3,00 - 3,50 - 4,00 - 4,50 - 5,00 - 6,00 - 7,00 - 8,00 - 10,00.

RBM spa reserves the right to improve and change the described products and related technical data at any moment and without prior notice: always refer to the instructions attached with the supplied components; this sheet is an aid, should the instructions be extremely schematic. Our technical department is always at your disposal for any doubt, problem or clarification.

RBM Spa

Via S. Giuseppe, 1 • 25075 Nave (Brescia) Italy
Tel 030 2537211 • Fax 030 2531798 • info@rbm.eu • www.rbm.eu

 @rbmspa  RBM S.p.A.  rbm_spa_  Rbm Italia