



AIRTERM MAG

Combined self-cleaning Dirt separator / deaerator

RBM Airterm Mag combines the functions of common dirt separators and deaerators in a single solution. They are used to remove air and impurities from hydraulic circuits. In addition, is equipped with a powerful magnet to capture particles such as rust and sand that are formed due to corrosion and scale during the normal operation of a system.

ADVANTAGES

Merging two different components into one solution has allowed us to significantly reduce overall dimensions with respect to the installation of two separate products: dirt separator + deaerator.



MAXIMUM DISCHARGE PRESSURE **10 bar**



AIRTERM MAG
Magnetic dirt separator / deaerator

Eliminates all impurities

Self-cleaning

Ensures system efficiency

Large capacity discharge

High performance (max. discharge pressure 10 bar)

Multifunction: Built-in dirt separator and deaerator

Magnetic

Bi-directional

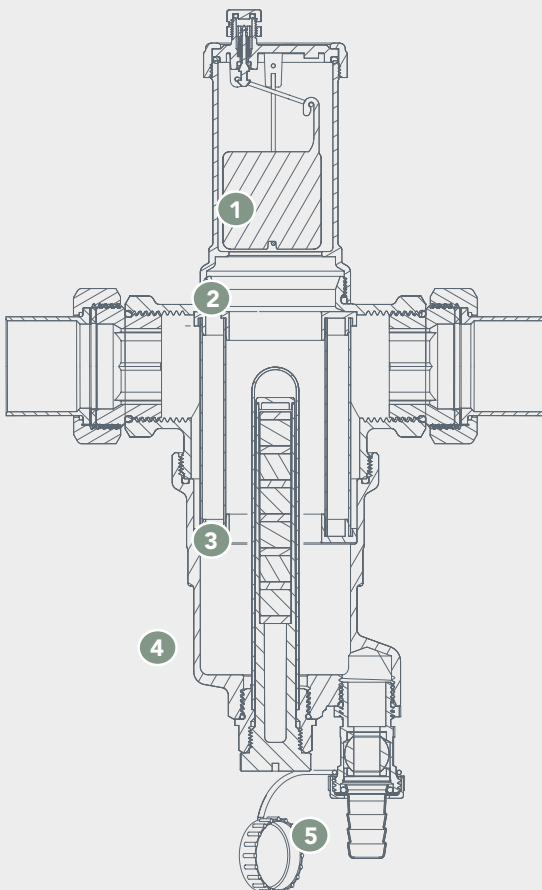

1 Passive part
High-performance air vent valve (discharge guaranteed up to 10 bar)

2 Innovative cartridge
Made up of stainless steel sheets with different filtering grades. Stainless steel is an exceptional guarantee of long service life, maximum reliability in variable pressure, temperature, greater resistance to corrosion and wear conditions, generated by impurities (as it is increasingly less possible to predict what they are comprised of). The flow goes directly through the cartridge and the continuous changes in sections lead to the creation of micro swirling movements which promote the release of micro bubbles. The micro bubbles settle on the internal metal cage and, after reaching an adequate size, they move upwards and are ejected by the passive part of the device. At the same time, this contributes to minimising the possibility of impurities running through and offers little resistance to the flow passage, characterised by very low head loss. The special cartridge does not obstruct the descent of the dirt into the accumulation zone in any way, therefore there is no danger of the particles being recovered by the flow running towards the outlet of the dirt separator



3 Magnet
(Only available in the RBM Airterm Mag device)
Powerful magnet to capture particles magnetic that are formed due to corrosion during the normal operation of a system



4 Accumulation area
Large and very far from the flow passage, resulting in less frequent maintenance work

5 Purge valve
Adjustable, with hose connector and safety cap