



Rev. 06/2025

RINOX INFINITY

Diaphragm pressure reducers.

RINOX INFINITY

Diaphragm pressure reducers.

+ For plumbing and heating systems

They reduce the pressure between the distribution network and the main user branches

For circuits where the upstream pressure is subject to fluctuations



PRODUCTION RANGE

"RINOX INFINITY" FIRST-STAGE PRESSURE REDUCER

Code	Measure	Connections	Max. upstream pressure	Adjustable downstream pressure
42910400	G1/2"	FF UNI-EN-ISO 228	25 bar [2500 kPa] (cold water 40°C) 16 bar [1600 kPa] (hot water 80°C)	100–550 kPa [1–5.5 bar]
42910500	G3/4"	FF UNI-EN-ISO 228	25 bar [2500 kPa] (cold water 40°C) 16 bar [1600 kPa] (hot water 80°C)	100–550 kPa [1–5.5 bar]
42910600	G1"	FF UNI-EN-ISO 228	25 bar [2500 kPa] (cold water 40°C) 16 bar [1600 kPa] (hot water 80°C)	100–550 kPa [1–5.5 bar]
42910480*	External: G 3/4"	MM UNI-EN-ISO 228	25 bar [2500 kPa] (cold water 40°C) 16 bar [1600 kPa] (hot water 80°C)	100–550 kPa [1–5.5 bar]
	Internal: G 1/2"	FF UNI-EN-ISO 228		

* Includes one fitting: M 1/2" - F3/4"

PRODUCT RANGE - ACCESSORIES

Code	Description
------	-------------



2574005

Radial pressure gauge ø 50. Full scale: 0 ÷ 10 bar. Connection: 1/4"

DESCRIPTION

The **RINOX INFINITY pressure reducer** is a diaphragm-type pressure reducer, equipped with a compensation chamber featuring an inspectable and replaceable internal cartridge with a graduated adjustment scale.

PURPOSE

The main purpose of **the RINOX INFINITY pressure reducer** is to reduce fluid pressure to optimal operating values, consistently below the maximum allowable limits to prevent damage to downstream equipment.

USE

The **RINOX INFINITY pressure reducer** is a **control device, not a safety device**. For this purpose, equip the system with the appropriate safety devices.

The **RINOX INFINITY pressure reducer** is particularly suitable for use in plumbing and heating systems. In particular, it is designed to reduce the pressure between the distribution network and the main user branches.

The pressure reducer is particularly suitable for use in circuits where the upstream pressure is subject to fluctuations (water hammer phenomenon).

These fluctuations are controlled by the compensation chamber within the reducer.

CERTIFICATIONS

All components suitable for conveying potable fluids comply with Ministerial Decree No. 174 of April 6, 2004, regarding materials and objects that may be used in fixed systems for the collection, treatment, conveyance, and distribution of water intended for human consumption, and to French Circular DGS/SD 7 A No. 2002-571 of November 25, 2002, which regulates the suitability of materials for contact with fluids intended for human consumption. The RINOX INFINITY pressure reducer has obtained the Attestation de Conformité Sanitaire (ACS) certification.

THE CHOICE

The downstream pressure adjustment range can be 1 bar to 5.5 bar.

The pressure reducer is factory-set with an outlet pressure of 3 bar.

Selecting the correct number of pressure reducers required to achieve the desired pressure reduction is important to prevent cavitation. Such phenomena, in fact, create excessive noise in the regulator, resulting in annoyance for users and possible damage to the regulator itself.

For further details, please refer to the dedicated section within the technical data sheet for the optimal selection of the number of regulators based on the pressure drop to be achieved.

CONSTRUCTION FEATURES

Body	Brass CW 617N
Sealing Seat	AISI 303 Stainless Steel
No. of valve seat sealing surfaces	1
No. of piston slide seal seats	1
Internal component material	CW 617N brass
Auction	Brass CW 617N
Diaphragm	EPDM Perox
Seals	EPDM Perox
Plastic parts	High-strength engineering polymer
Pressure gauge connection	F G 1/4"

FEATURES TECHNIQUES

Compatible fluid	Water
Rated pressure	PN25 (cold water 40°C) / PN16 (hot water 80°C)
Inlet pressure in accordance with NF standard	16 bar
Adjustable downstream pressure	1–5.5 bar
Factory preset	3 bar
Maximum operating temperature	80 °C
Connections	UNI-EN-ISO 228 FF thread or MM union, depending on model
Water hammer protection	Yes

DIMENSIONAL CHARACTERISTICS

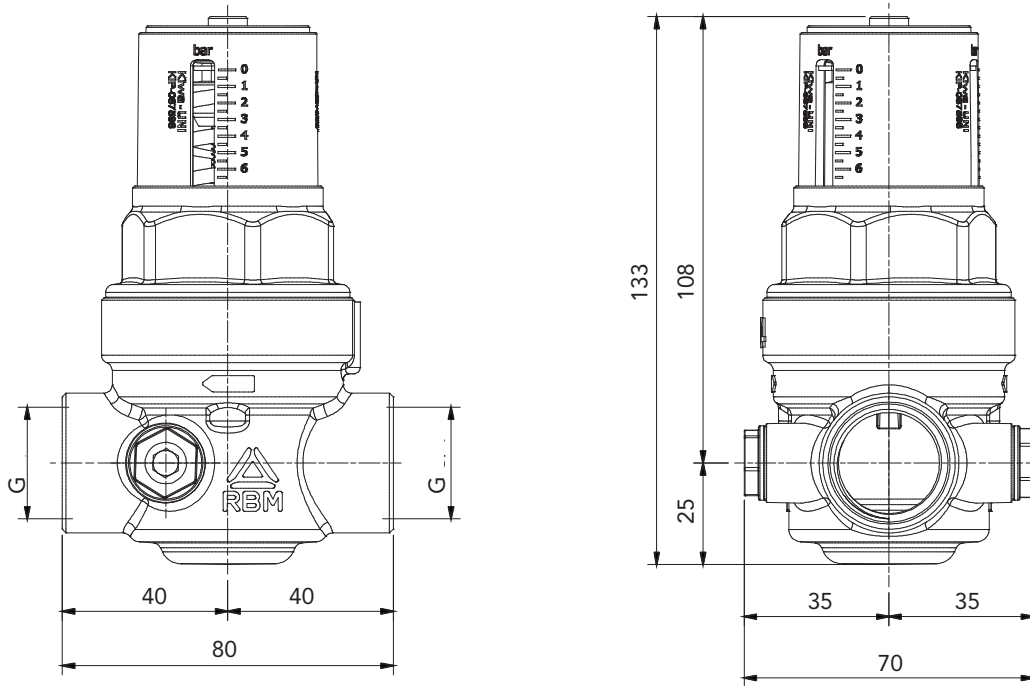

CONFIGURATION 1 - RINOX INFINITY

Code	Measure G
42910400	FF 1/2"
42910500	FF 3/4"
42910600	FF 1"

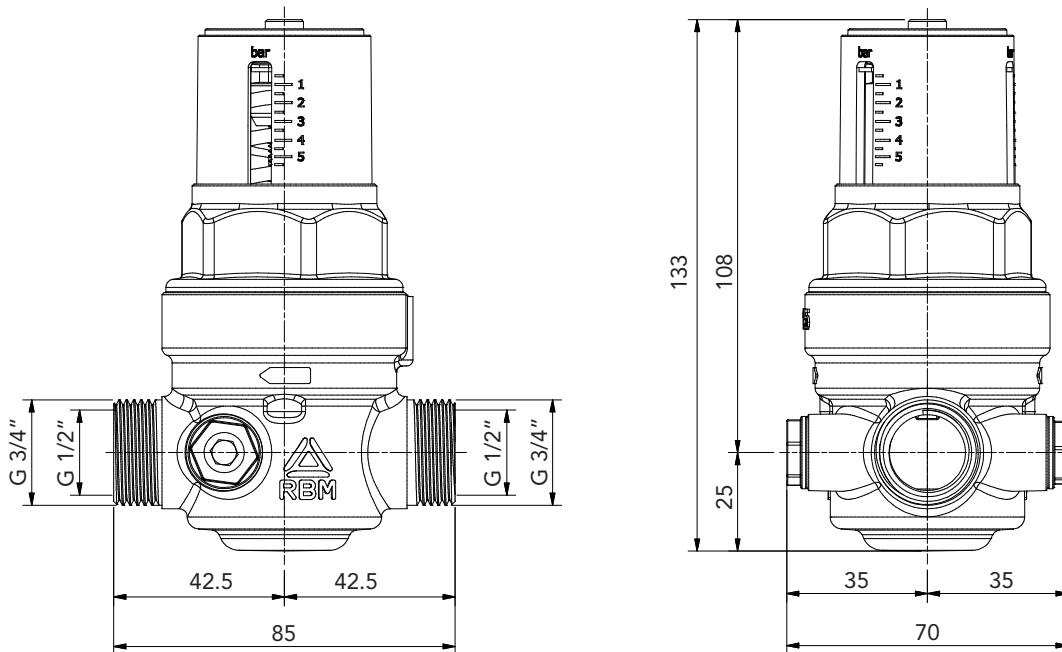

CONFIGURATION 2 - RINOX INFINITY

Code	Measure
42910480	3/4" MM x 1/2" FF

DIMENSIONAL CHARACTERISTICS

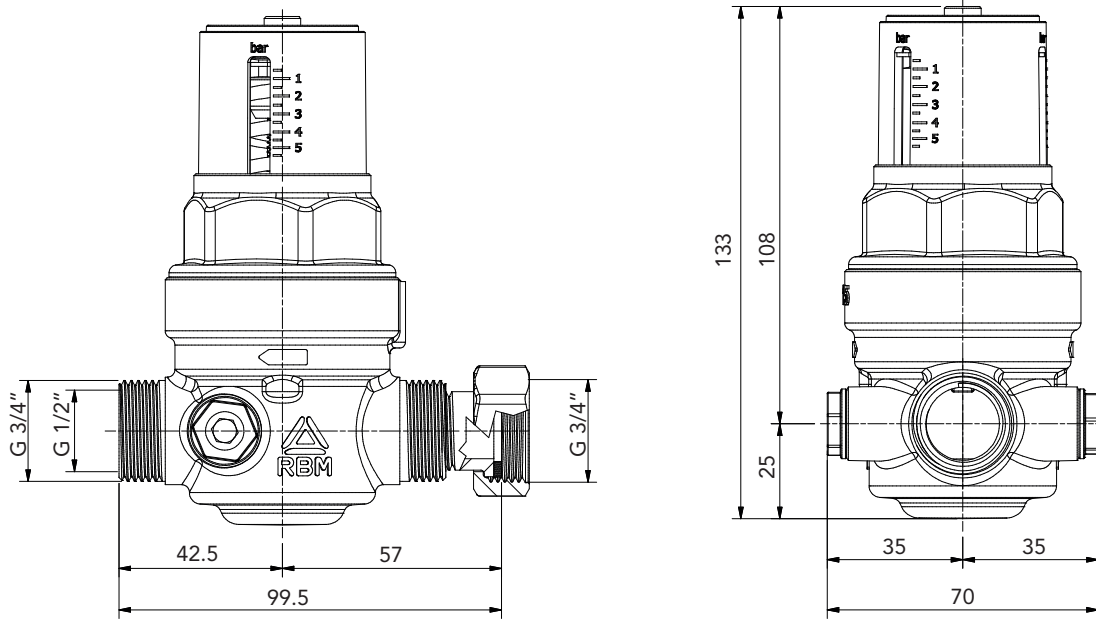

CONFIGURATION 2.1 - RINOX INFINITY

Code	Measure
42910480	3/4" MM x 1/2" FF

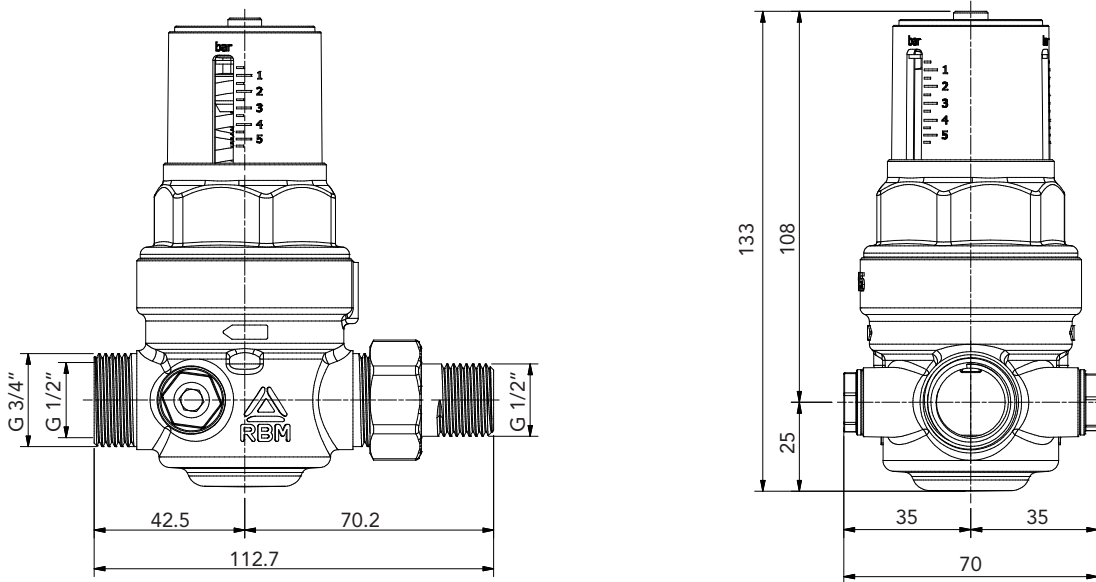

CONFIGURATION 2.1 - RINOX INFINITY

Code	Measure
42910480	(3/4" male x 1/2" female) x 1/2" male

PRINCIPLE OF OPERATION

The **RINOX INFINITY pressure reducer operates by** balancing the opposing force of the spring against the thrust exerted by the fluid pressure on the diaphragm. In fact, the spring tends to open the regulator's valve, while the pressure exerted on the effective surface of the diaphragm tends to close the valve.

The **RINOX INFINITY pressure reducer, based on** the compensation chamber system, eliminates variations that could result from pressure fluctuations in the upstream circuit. The compensation chamber, in fact, distributes the pressure evenly across the valve's ends. In this way, the pressure regulation performed by the regulator will depend solely on the required downstream pressure value.

PRESSURE REMAINS AT THE SET VALUE OF 3 BAR

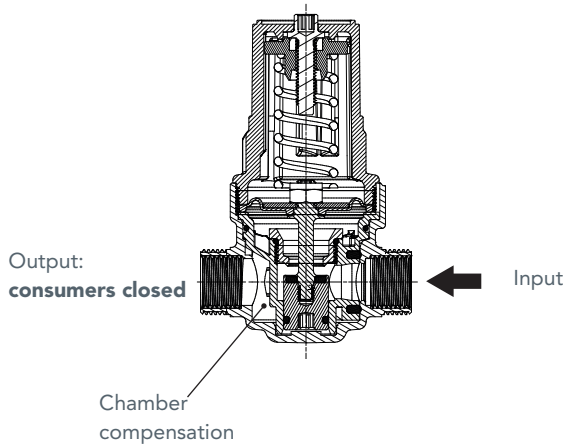

PRESSURE DROP: $P < 3$ BAR

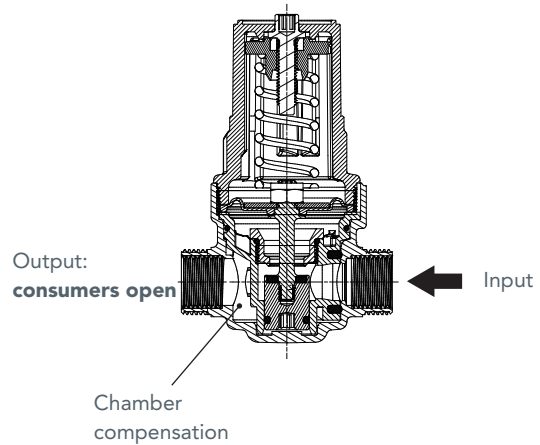

When the outlets to be served are closed, the downstream pressure increases, pushing the pressure reducer's piston downward. In this way, the spool closes the flow path of the regulator, maintaining the pressure constant at the set value determined by the spring; the minimal pressure difference across the spool ensures its perfect closure.

When the downstream outlets open, the pressure exerted on the piston is relieved, allowing the spring's force on the shutter to open it, thereby allowing fluid to flow through. The higher the water demand from the user network, the lower the pressure on the piston becomes, and the greater the water flow will be.

PRESSURE REDUCER CALIBRATION

The final calibration of the pressure reducer must be performed with the hydraulic circuit completely full and all outlets closed; otherwise, the readings would be distorted by the fact that, during any flow, the downstream pressure decreases in relation to the required flow rate.

The pressure reducer is calibrated by adjusting the internal ring nut or the external screw: turn clockwise to increase the value, and counter-clockwise to decrease it.

Calibration procedure:

- Close the shut-off valve downstream of the pressure reducer.
- Adjust the pressure reducer using the appropriate wrench.
- The adjustment is complete when the desired pressure is displayed on the pressure gauge.

Warnings:

- Perform a few discharge cycles to verify the stability of the calibration.
- When the system is running, the pressure reading on the pressure gauge may be distorted by overpressure in the heating system; any correction must always be performed with the system shut down and at room temperature.

FLUID DYNAMIC CHARACTERISTICS

Pressure drop diagram

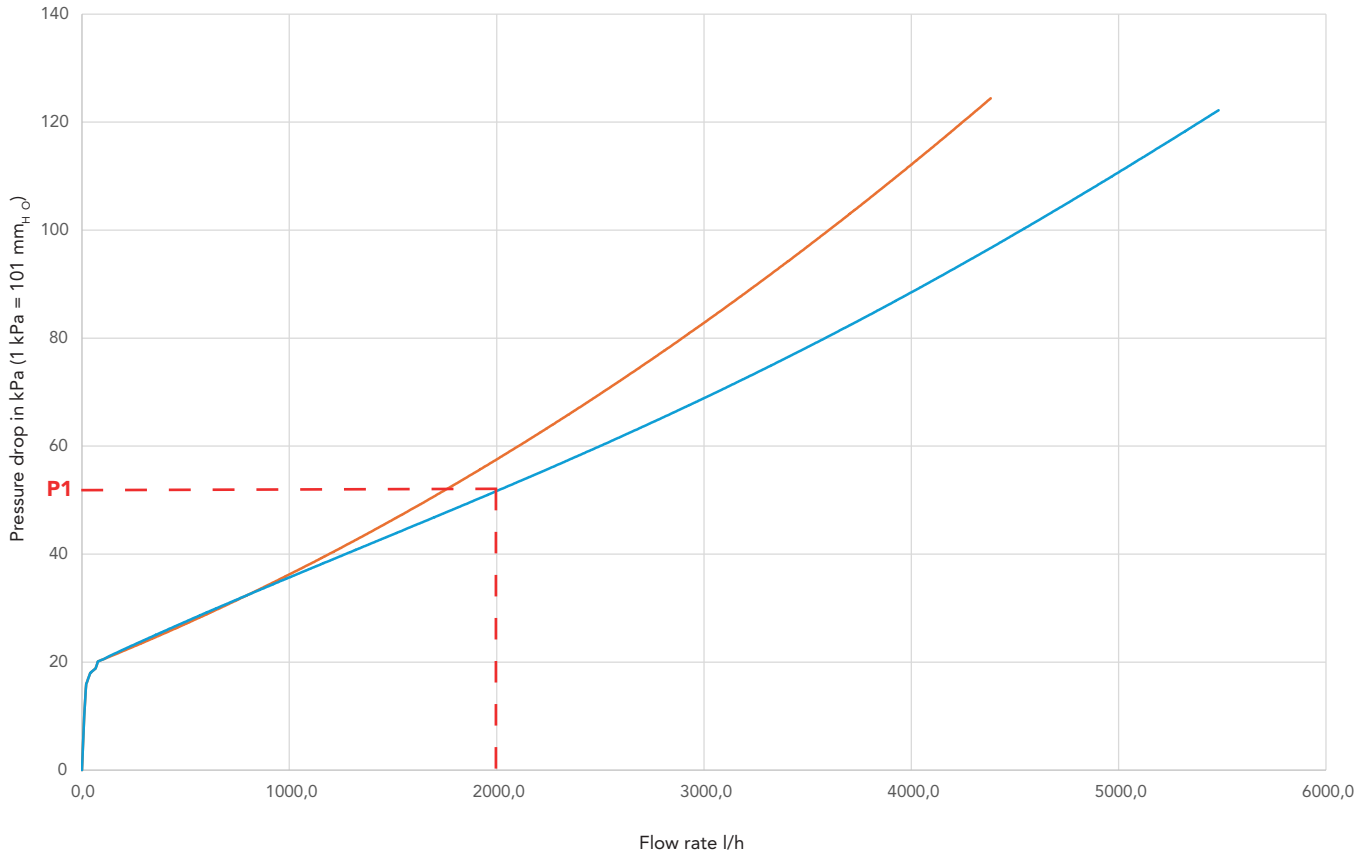

The values shown in the diagrams are obtained with:

- Upstream pressure of 800 kPa (8 bar);
- Downstream pressure of 300 kPa (3 bar).

The values shown refer to the performance of the Rinnox pressure reducer only

READING THE DIAGRAM:

The pressure reducer pressure drop diagram shows the pressure drop as a function of flow rate at the outlet of the loads.

Example: Consider the 3/4" pressure reducer with a preset pressure of $P = 300$ kPa and assume a flow rate of $Q = 2000$ l/h at the outlet to the service point. From the diagram, we see that for this flow rate Q , the pressure drop is $s_{p1} = 50$ kPa. On the pressure reducer's pressure gauge, the following pressure value will be read: $P = 300 - 50 = 250$ kPa, which therefore represents the outlet pressure at the outlet at the desired flow rate.

SIZING THE PRESSURE REDUCER

Cavitation diagram*

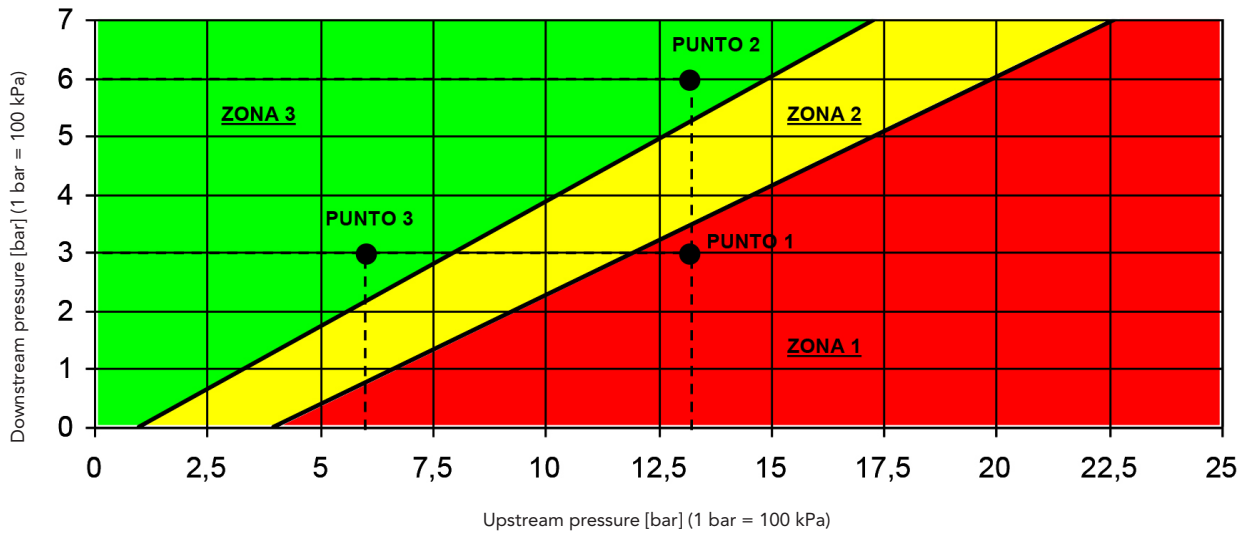

To avoid cavitation and consequently excessive noise from the component, it is recommended to size the number of pressure reducers required for a given pressure drop according to the "CAVITATION DIAGRAM."

The cavitation diagram shows three operating zones for the pressure reducer based on the inlet and outlet pressures:

- **ZONE 1: Malfunction zone.** Cavitation phenomena are clearly visible and present inside the regulator: avoid operating the regulator at these pressures.
- **ZONE 2: Critical zone.** Cavitation phenomena may occur inside the reducer. IT IS not recommended to use the gearbox within this pressure range.
- **ZONE 3: Operating zone.** The pressure reducer operates under optimal conditions and does not cavitate. This pressure range is optimal for the regulator's operation.

To avoid cavitation, it is recommended to operate the regulator within ZONE 3 and, furthermore, to ensure that the ratio between the maximum inlet pressure and the set pressure downstream of the regulator does not exceed 2.5.

SIZING

If you want to operate a pressure reducer within the following pressure ranges:

- Upstream pressure: $p_M = 13$ bar
- Downstream pressure: $p_V = 3$ bar

As shown in the diagram (POINT 1), at these operating pressures, the pressure reducer will experience cavitation.

To avoid this and considering that the ratio between the maximum inlet pressure and the outlet set pressure must not exceed 2.5, a second pressure reducer can be installed in series to achieve the same pressure drop through two separate pressure drops.

The proposed solution, therefore, is to use two pressure reducers in series, both of which must operate in ZONE 3 of the diagram, distribute the pressure difference across two reduction steps, and ensure that the pressure ratio does not exceed 2.5.

POSSIBLE SOLUTION:

Pressure reducer A [POINT 2]:

- Upstream $P_{PMA} = 13 \text{ bar}$
- Downstream pressure: $P_{PVA} = 6 \text{ bar}$

Pressure ratio: $13/6 = 2.17 < 2.5$

Note: The pressure downstream of the regulator must never exceed the maximum operating pressure of the components located downstream of the regulator itself, in order to prevent damage or malfunction.

Cavitation in the pressure reducer can be controlled not only by adjusting the pressure drop but also by selecting an optimal flow velocity for the fluid passing through it.

IT IS therefore advisable to select the diameter of the pressure reducer so that the fluid velocities passing through it fall within the following ranges:

- **For water:** $V = 0.7 \div 1.5 \text{ m/s}$ (residential use)
 $V = 1 \div 3.5 \text{ m/s}$ (industrial use)

* **No.B:** The cavitation diagram is intended solely to provide the technician with a quick, general reference for matching the selected component to a specific system size. The values shown in the table are not binding and therefore do not represent the performance limits of the components

INSTALLATION

INSTALLATION PRECAUTIONS:



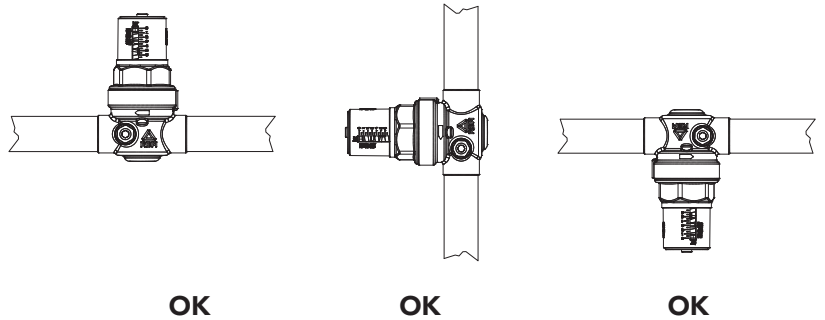





- Always install a filter upstream of the system.
- Perform routine maintenance on the filters.
- Observe the direction indicated by the flow direction arrow on the body.
- Use shut-off valves to allow for any maintenance work.
- Clean the piping upstream and downstream of the pressure reducer to prevent damage.
- The pressure reducer can be mounted vertically, horizontally, or facing downward.





RECOMMENDATIONS REGARDING PERMITTED CONNECTION METHODS FOR THREADED CONNECTORS:

To ensure proper sealing of threaded joints and fittings in hydraulic, sanitary, and industrial systems, it is recommended to use appropriate sealants, pastes, and/or products suitable for sealing such connections. The use of flat-seal and/or conical gaskets, or any other type, is not permitted.

MAIN COMPONENTS COMPATIBLE WITH THE RINOX INFINITY PRESSURE REDUCER

	Code	Description
	3.03÷13.00, 3.03÷13.10, 3.03÷09.70, 3.03÷13.20	In-line filters with removable filter cartridge. Max. operating pressure: 16 bar. Thread: UNI-EN-ISO 228. Filter capacity from 800 µm to 50 µm.
	858.04÷09.12, 858.04÷09.02, 858.04÷09.72	In-line filters with removable filter cartridge. Max. operating pressure: 16 bar. Thread: UNI-EN-ISO 228. Filter capacity from 800 µm to 100 µm.
	126.03÷13.10	Self-cleaning water filter with removable filter cartridge, complete with dial pressure gauge and ball valve drain with hose connection. Max. operating pressure: 16 bar. Thread: UNI-EN-ISO 228. Filter capacity 100 µm
	2516.04–06.00 (compact) 583.07.00	Self-cleaning water filter with removable filter cartridge and visual clogging indicator, complete with dual dial pressure gauge and ball valve drain with hose connection. Max. operating pressure: 16 bar. Thread: UNI-EN-ISO 228. Filter capacity 100 µm
	Series 929, 930, 931, 959, 1041, 1156, 1171, 1172, 1173, 1200, 1201, 1215, 6059, 6062, 6065, 6068, 6071, 6074	Replacement cartridge for in-line, Y-type, self-cleaning filters with single and dual pressure gauges.
	304.04–13.00	Magnetic scale inhibitor for physical water treatment. Max. operating pressure: 16 bar. Thread: UNI-EN-ISO 228.
	67.04÷07.02, 67.04÷07.12	Full-bore ball valve for water, operated by a butterfly handle, MF connections. Thread: UNI-EN-ISO 228.
	67.05.70, 67.06.70, 67.05.00, 67.06.00	Full-bore ball valve for water, operated by a butterfly handle, MF connections with O-ring seals. Thread: UNI-EN-ISO 228.

MAIN COMPONENTS COMPATIBLE WITH THE RINOX INFINITY PRESSURE REDUCER

	Code	Description
	72.04÷09.00, 72.06.50	Three-piece straight MM union fitting. Max. operating pressure: 10 bar. Thread: UNI-EN-ISO 228.
	1100.05.00, 1100.06.00	Three-piece straight MM union fitting with O-ring seals on the connections. Max. operating pressure: 10 bar. Thread: UNI-EN-ISO 228.



STORAGE WARNINGS

Store the product in its original packaging or a sealed container in a clean area protected from freezing, moisture, direct sunlight, heat sources, open flames, or ignition sources. Avoid sudden temperature fluctuations by maintaining optimal temperature and humidity conditions (temperature 10–35 °C / humidity <80%). Ensure there is no risk of damage due to the presence of other materials or possible tampering by unauthorized persons.

RBM spa reserves the right to make improvements and changes to the products described and their technical data at any time and without prior notice. The information and images contained in this document are provided for informational purposes only and are not binding. In any case, they do not exempt the user from scrupulously following current regulations and good technical standards.

RBM Spa
Via S. Giuseppe, 1 • 25075 Nave (Brescia) Italy
Tel 030 2537211 • Fax 030 2531798 • info@rbm.eu • www.rbm.eu

@rbmspa RBM S.p.A. rbm_spa_ Rbm Italia